

## TPA-1820A-03

GSM1800 Tower-Mounted Booster, Channel-Selective

### Features

- High downlink power of 40dBm per carrier provides for extended cell coverage.
- Channel-selective module permits 2 downlink carriers on a single feeder cable.
- Low noise amplifier reduces uplink system noise figure and results in reduced dropped call and better voice quality.
- Reduces handset output power for improved uplink C/I.
- Alarms can be sent via BTS alarm relay contacts for easy operation and maintenance.
- Automatic bypass feature permits BTS operation when TPA or power supply fails.
- Designed for all weather – waterproof, damp-proof and omni-sealed (IP65).
- Permits local monitoring via notebook computer and remotely by wire or GSM modem.
- Alarms can be transmitted to OMC via data call or SMS.
- Internal battery backup ensures alarm messages are transmitted when power fails.



### Product Description

The TPA-1820A-03 is a GSM1800 tower-top power amplifier (PA) that provides both uplink and downlink amplification for 4 carriers. The tower-top PA unit is installed near the antenna at the tower top to raise the transmitted power for extended cell coverage. The uplink low-noise amplifier (LNA) serves to improve the sensitivity of the BTS to cope with the extended cell coverage in the downlink. The frequency-selective module in the downlink permits 2 carriers on a single feeder cable.

The TPA is powered through a separate power cable, with various power supply options. The system comprises of duplexers, uplink LNA, downlink PA, Frequency Selecting and Amplifying Module (FSA), RF by-pass switch, main control unit (MCU), RS232 board, power supply unit, lightning arrestor, wireless GSM modem, and backup Li-on battery. Parameter settings of the TPA can be done locally via a notebook computer with installed OMT software, or remotely via wireless modem using OMC software. Alarms are displayed on the MCU and will trigger the BTS external alarm. Through the wireless modem, the alarm data can be transmitted to the OMC automatically, or be sent as SMS to the maintenance personnel's handset.

### Block Diagram

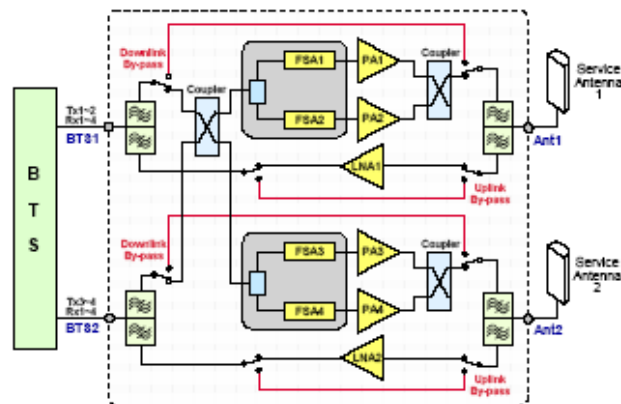

# TPA-1820A-03

GSM1800 Tower-Mounted Booster, Channel-Selective



## Technical Specifications

### Electrical

Frequency Range, UL - [MHz]	1710 - 1785
Frequency Range, DL - [MHz]	1805 - 1880
Number of Carriers	4
Output Power per Carrier - [dBm]	40
Max. System Gain - [dB]	
- Uplink	12 ± 1.0
- Downlink	16 ± 1.5
Gain Adjustment Range - [dB]	
- Uplink (1dB step)	0-12 ± 1
- Downlink (1dB step)	0-20 ± 1
Input Power Range, DL - [dBm]	30 - 40 / carrier
Passband Ripple, p-p - [dB]	
- Uplink	≤ 2.5
- Downlink	≤ 3.0
Selectivity, DL - [dB]	
- at ±100kHz	≥ -3
- at ±400kHz	≤ -35
- at ±600kHz	≤ -60
Spurious - [dBm]	
- 9kHz - 1GHz	≤ -36
- 1 - 12.75 GHz	≤ -30
Noise Figure, Uplink - [dB]	≤ 3 (typ. 2.5)
By-pass Loss - [dB]	≤ 3.0
System Group Delay - [µsec]	≤ 8.0
Max. RF Input Power - [dBm]	
- Uplink	+13
- Downlink	+43 / carrier
VSWR	≤ 1.4
Impedance - [Ω]	50

### Power, Mechanical, Environmental

Power Supply Options	155-285VAC/ 45-55Hz or -48 VDC or +24 VDC
Power Consumption - [W]	350 (approx.)
MCU Battery Backup Time - [hr]	6 (approx.)
Power Up Waiting Time - [sec]	60 (approx.)
Dimensions, HxWxD - [mm]	600 x 450 x 295
Weight - [kg]	51 (approx.)
RF Connector	4x 716-Female or 4x N-Female
Operating Temperature - [°C]	-40 to +55
Operating Humidity - [%]	≤ 95
Cooling	Convection
MTBF - [hrs]	> 50,000
Environmental Class	IP65

### Operation & Maintenance

Local Monitoring Feature	PC via RS232
Remote Monitoring & Transmission Feature	via build-in wireless GSM modem or Short Message (SMS)
Local and Remote Controlled Parameters	Channel No, UL/DL ATT, Soft ON/OFF, Over-Temp Threshold, DL Output Power Threshold, DL Input Power Threshold, Alarm Report Enable
Local and Remote Monitored Parameters	Alarms (LNA, DL PA, Power Down, PSU Fault, Door Open, DL Input Power Low, DL Output Power Low, Over Temp, VSWR), Temp, UL/DL Gain, DL Output Power, DL Input Power

## Mechanical Outline Drawing

