

Features

- Dual band-selective modules with user-defined bandwidth and adjustable centre frequency.
- Integrated GSM/CDMA radio modem for remote configuration, monitor and control.
- Automatic gain stabilization prevents self oscillation caused by a low isolation between DT and MT antennas.
- Internal backup battery keeps the alarm unit running for up to 6 hours after power loss.
- Optional OMC is available for remote operation and maintenance of repeaters.
- Designed for all weather outdoor - waterproof, damp-proof and omni-sealed (IP65).



Product Description

The R-1810DB dual band-selective repeater is designed for outdoor operation in the GSM1800 band. Band-specific linear amplifier and filtering effectively amplifies the desired BTS carrier and provides superior out-of-band rejection. Typical units incorporate up to 25MHz channel bandwidth with frequencies customised to specific requirements of the network. Remote configuration and surveillance is possible through Comba's remote control and monitoring system, via laptop or wireless modem to the OMC. Li-ion battery backup ensures alarm signals are sent out in the event of power failure, and full battery backup option ensures operation in unstable mains supply. The R-1810DB comes in a completely sealed, well-ventilated cast aluminum chassis, suitable for all weather conditions (IP65).

System Block Diagram

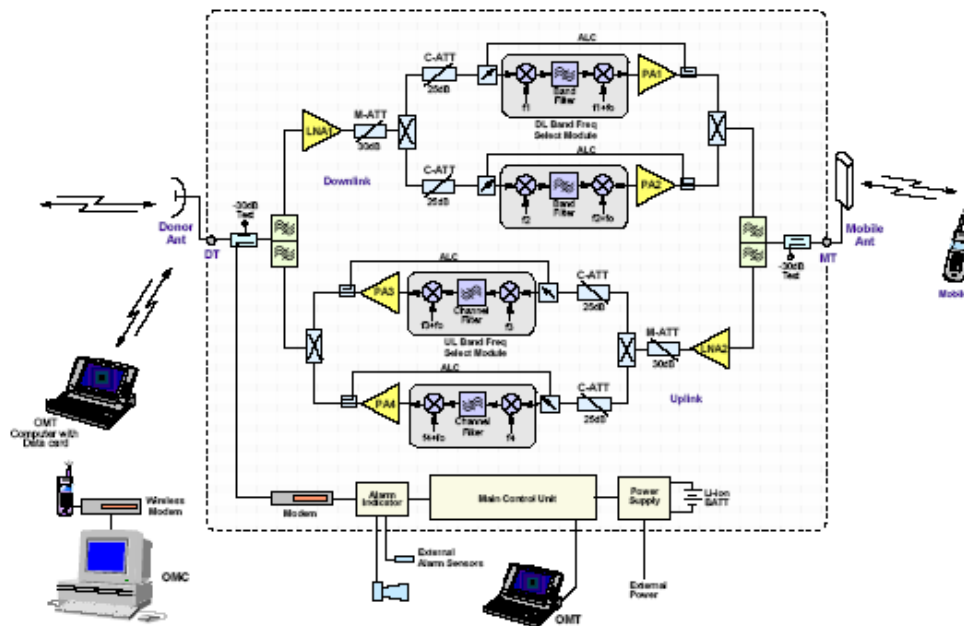

Technical Specifications

Electrical, Power

Frequency Range, Uplink - [MHz]	1710 - 1785
Frequency Range, Downlink - [MHz]	1805 - 1880
Operating bandwidth*, Bw - [MHz]	24.2 and 25.0
Centre Frequency	Adjustable Full Band
Max. System Gain - [dB]	90 ± 2
Gain Adjustable Range (1dB step) - [dB]	0-30 ± 1.5
Max. Output Power (with ALC) - [dBm]	30 ± 1
Pass Band Ripple, p-p - [dB]	≤ 4
System Noise Figure - [dB]	≤ 4
Group Delay - [µsec]	≤ 6
Band Selectivity - [dB]	
- at Bw	≥ -3
- at Bw+1.2MHz	≤ -45
- at Bw+2MHz	≤ -60
Spurious - [dBm]	
- 9kHz to 1GHz	≤ -36
- 1GHz to 12.75GHz	≤ -30
Intermodulation - [dBm]	≤ -30
@ Pout = 30Bm	
Max. RF Input Power - [dBm]	+13
Input VSWR	≤ 1.5:1
Impedance - [Ω]	50
Power Supply - [VAC]	155-285/ 45-55Hz
Power Consumption (approx) - [W]	100
MCU Battery Backup Time - [hr]	6 (approx.)
Power Up Waiting Time - [sec]	60 (approx.)

Mechanical, Environmental

Dimensions, L x W x H - [mm]	600 x 450 x 195
Housing Material	Aluminum
Housing Colour	Grey Anodised, RAL877U
Weight - [kg]	37 (approx.)
Connector Type	2x N-Female or 7/16 DIN Female
Operating Temperature - [°C]	-40 to +55
Operating Humidity - [%]	≤ 95
Cooling	Convection
MTBF - [hrs]	> 50,000
Environmental Class	IP65

Operation & Maintenance

Local Monitoring Feature	PC via RS232
Remote Data Transfer	via Line modem, build-in wireless GSM modem (data or SMS)
Local and Remote Controlled Parameters	Channel No, Range, ATT, Soft ON/OFF, Oscillation Elimination ON/OFF, Over-Temp Threshold, UL/DL Output Power Threshold, DL Input Power Threshold, VSWR Threshold, Alarm Report Enable
Local and Remote Monitored Parameters	Alarms (LNA, PA, PLL unlock, Power Down, PSU Fault, Door Open, Self oscillation, DL Input Power Low, Over Temp, VSWR, UL/DL Output Power Low), UL/DL Output Power, DL Input Power

* - Customised to user's band

Mechanical Outline Drawing

